

D2

TRACK-TYPE TRACTOR



Net Power (2,200 rpm)

SAE J1349, ISO 9249, 80/1269/EEC 68.8 kW (92 hp)

Operating Weight

D2 8338 kg (18,382 lb)

D2 LGP 8648 kg (19,066 lb)

Cat® C3.6 Engine meets U.S. EPA Tier 4 Final/Japan 2014 (Tier 4 Final)/Korea Tier 4 Final/EU Stage V emission standards.



The new **Cat® D2** succeeds the renowned D4K2 with superior performance and the broadest choice of technology features to help you get the most from your dozer. Nimble and responsive, it has power for dozing and finesse for grading. Fully hydrostatic transmission gives you seamless acceleration, so you can get the job done quickly.

THE NEW CAT® D2

PERFORMANCE AND
TECHNOLOGY



D2 68.8 kW/92 hp 8338 kg/18,382 lb

D4K2 68.8 kW/92 hp 8168 kg/18,007 lb

NEW NAMES, SAME WORLD-CLASS PERFORMANCE

The update from D4K2 to D2 is part of an effort to make all Cat dozer model names simpler. Over the next couple of years, the Cat dozer range will be renamed from smallest to largest – D1 to D11 – with one model per size class and no more letter modifiers like “N,” “K,” “T.”

While the number may be different, the D2 gives you all the advantages of the D4K2 and so much more. The D2 delivers more technology, better visibility and more performance, helping you make the most of your equipment investment.

SETTING THE STANDARD

FROM FIRST PASS
TO FINISH GRADE



IMPROVED VISIBILITY

The angle of the hood was increased to enhance the peripheral vision for the operator. This new sloped hood allows for better assessment of the work in front of the blade and job site awareness. Better visibility can equal less operator fatigue and more confidence in your work.

GRADE TECHNOLOGY

GRADE with 3D and Slope Assist™ help achieve the best quality grading results, while new technologies make machine operation easier and more efficient.

UP TO 10% IMPROVED FUEL ECONOMY

- + Lowers operating costs to the customer
- + Lowest fuel consumption in this size class
- + Still same great performance you've come to expect
- + Up to 20% improvement and no performance sacrifice with ECO mode active
- + Engine efficiency enhancements

OPERATOR STATION

THE COMFORT AND CONTROL FOR A PRODUCTIVE SHIFT



EASY OPERATION

The hydrostatic transmission provides infinite speed control – just choose the speed and go. The load sensing system automatically optimizes ground speed based on load, for the greatest productivity and fuel efficiency.

WORK SPACE

Regardless of operator stature, step into a spacious and comfortable cab that resets the industry standard. An optional heated and ventilated seat, along with heated joystick controls make the operator comfortable no matter what the conditions are outside. The seat height adjustment is now easier to access, and armrests can be quickly adjusted to operator's preference – no tools required!

A CAB EVERY BODY CAN LOVE

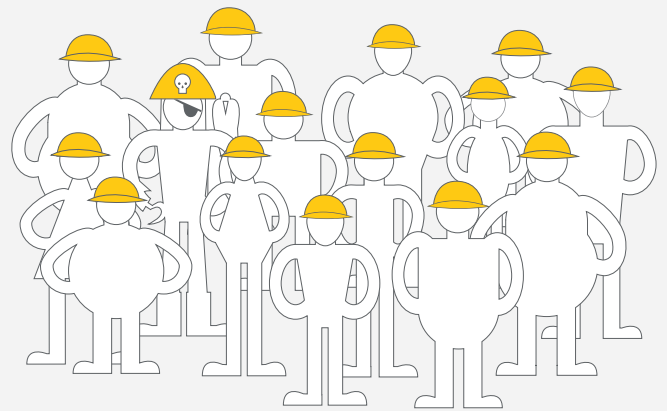

6 Seat Adjustments



UNBEATABLE VIEW

The best seat in the house just got an upgrade by way of improved visibility. The new, redesigned, sloped hood line allows the operator a wider peripheral view for better job site awareness and ease of operation.



BIGGER, BETTER DISPLAY WITH CAMERA

This new and improved optional 10 inch (254 mm) touchscreen, color display is easy to use, with a great view of machine settings, rearview camera and Slope Indicate/Slope Assist screens. The large reversing camera gives the operator better visibility to the job site as well as less fatigue at the end of the day.

Additionally, the Key Features button gives the operator an overview of machine features, along with some helpful operating tips.

CAT[®] GRADE

2D

- Cat Grade with Slope Assist
- Cat Grade with Laser

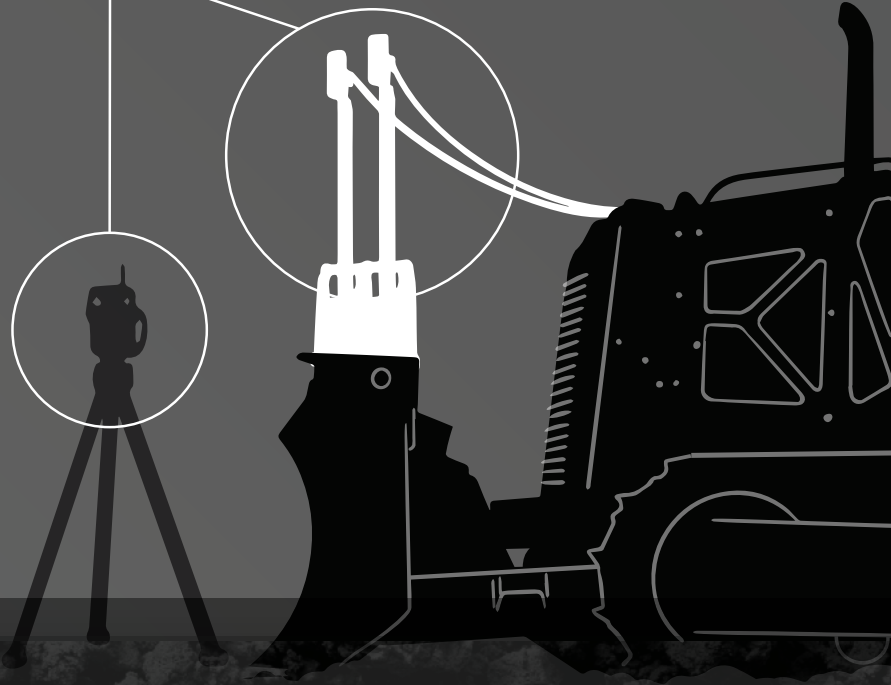

SCALABLE SOLUTIONS

3D

- Integrated GNSS
- Blade-mounted GNSS
- Blade-mounted Universal Total Station

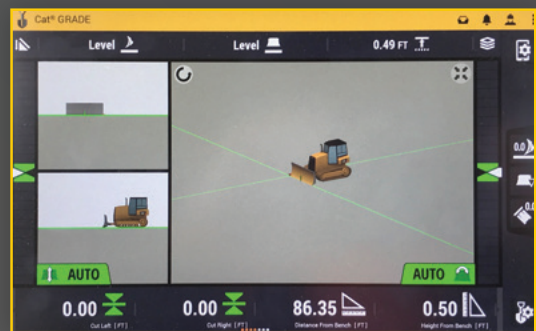

VALUE TO YOU

- Optional integrated, 10-inch (254 mm) color touch screen display
- Stable Blade and Slope Indicate are standard
- Capability to scale up technology, and the flexibility to adapt different technology based on job site demands
- Partnership and support from your Cat or SITECH® dealer

DURABILITY

UNMATCHED POWER WITHOUT COMPRISING MACHINE LONGEVITY

The Small Dozer final drive provides a large, double reduction planetary gear set that allows the machine to push heavy loads. The undercarriage has a longer life, less down time and is standard on all Cat Dozers. A one piece mainframe/track roller frame design gives the machine the strength to carry pushing loads.

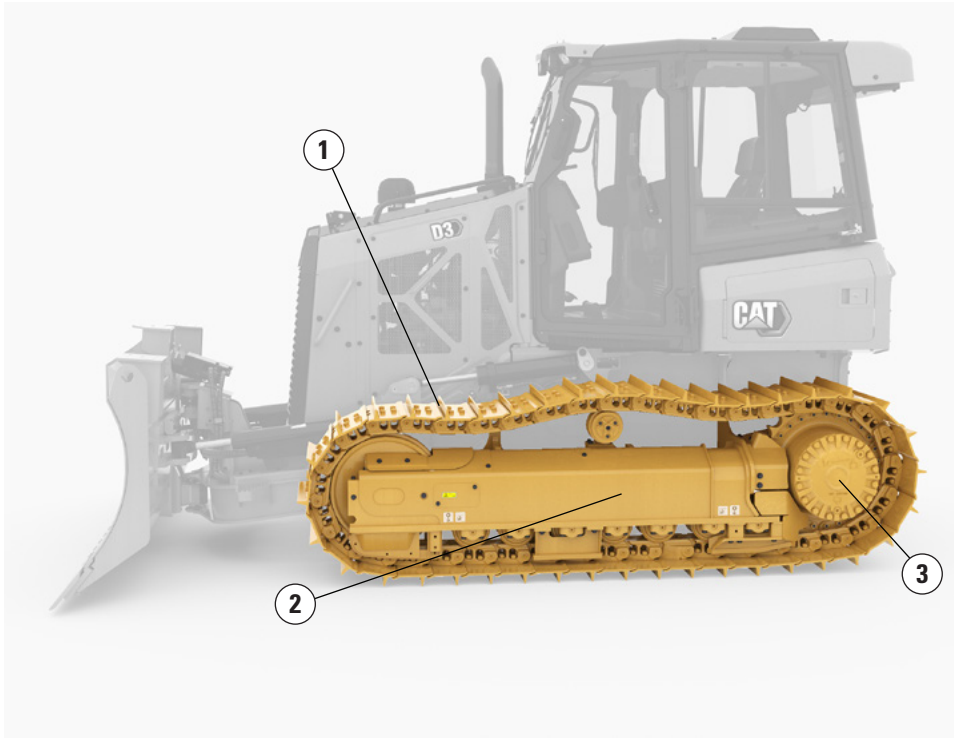

1. Two Track offerings: Sealed and Lubricated Track (SALT)/Abrasion
2. Track Roller Frame
3. Final Drive



FINAL DRIVE

- + Large planetary gear set
- + Heavy pushing load spread over multiple gears
- + Longer life and less down time
- + Standard on all Cat dozers



SALT

- + Cost effective
- + Eliminates internal pin and bushing wear
- + Long life
- + Universal applications



ABRASION

- + Longer undercarriage wear life
- + No link assembly maintenance
- + No downtime for bushing turns
- + Less cost per hour by using full link life without a bushing turn
- + For high-abrasion applications



PUSH MORE. GRADE MORE.
POWER YOU CONTROL.

AUTOMATIC TRACTION CONTROL

Reduces track slippage with no operator interaction resulting in less ground disturbance and less passes.

POWER TURN

Power to each track allows the dozer to carry heavy loads around turns.

COUNTER-ROTATION

Quick and easy spot turns, along with the ability to control dozer direction during heavy side loads.

SMOOTH CONTROLS

Controls with low operator effort provides predictable maneuverability.

VERSATILITY

SOLUTIONS TO SUIT YOUR UNIQUE APPLICATIONS AND WORK

We offer a full line-up of specialty dozer attachments and purpose built machine configurations for unique applications.

Configure your machine to the application.

FORESTRY

- + Sweeps
- + Screens
- + Hinged radiator grill
- + External Precleaner

PLUS

- + Fire plow – fire suppression
- + Ship hold – bulk material handling operations



WINCH

- + Retrieval – great performance, easy to install
- + High performance – maximum line speed and pull

RIPPER

- + Parallelogram linkage
- + 3 shank



MAINTENANCE

MAKING UPKEEP MANAGEABLE

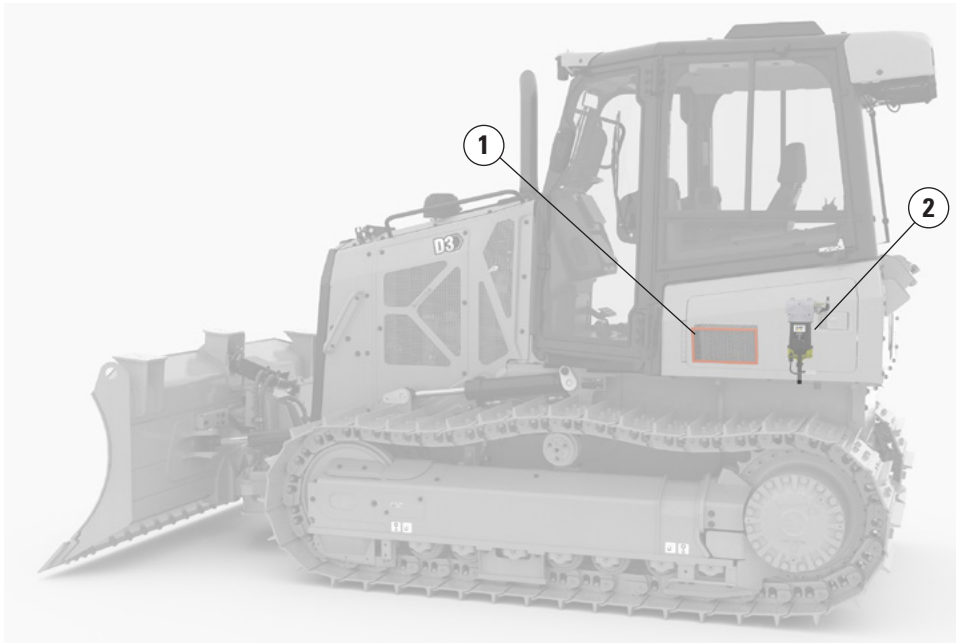

The Next Generation Small Dozers are easier than ever to service with ground level access to daily maintenance areas. Additionally, there are new options available to further simplify service with the turbine-type precleaner, reversing fan, and hinged radiator grill.

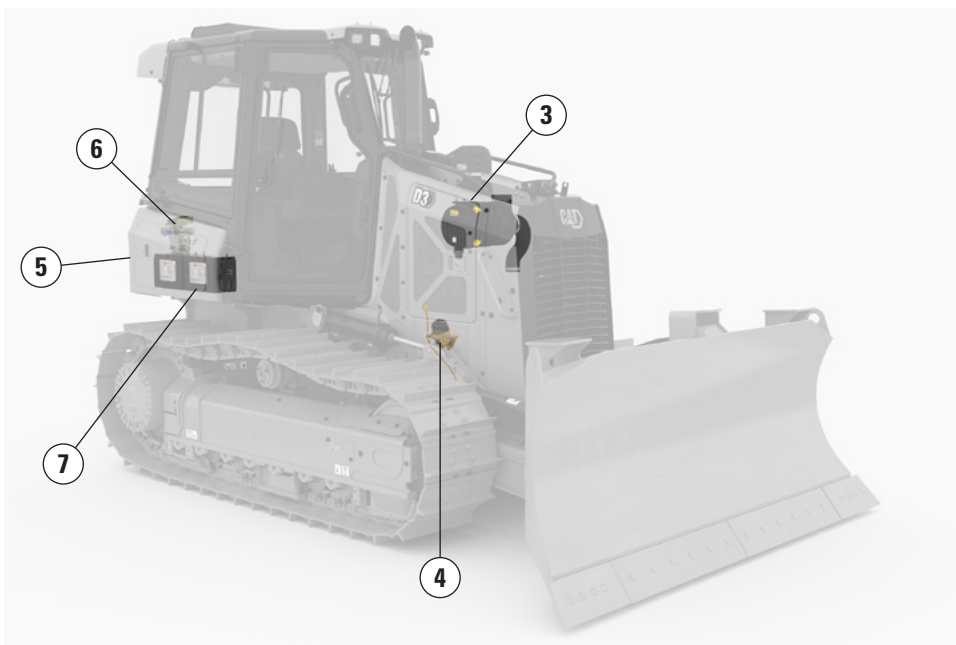

1. Cab air filter
2. Fuel filter
3. Engine air filter
4. Engine oil filter
5. Master disconnect switch
6. Hydraulic oil filter
7. Batteries

CAT DEALER SUPPORT

The Cat Dealer support network is truly the best in the business. They are there to support customers with the parts and service that optimize machine performance and life.

CAT LINK TECHNOLOGY

TAKES THE GUESSWORK OUT OF MANAGING YOUR EQUIPMENT

CAT LINK telematics technology helps take the complexity out of managing your job sites – by gathering data generated by your equipment, materials, and people – and serving it up to you in customizable formats.

CAT PRODUCT LINK™

Product Link™ collects data automatically and accurately from your assets – any type and any brand. Information such as location, hours, fuel usage, productivity, idle time, maintenance alerts, diagnostic codes, and machine health can be viewed online through web and mobile applications.



VISIONLINK®

Access information anytime, anywhere with VisionLink® – and use it to make informed decisions that boost productivity, lower costs, simplify maintenance, and improve safety and security on your job site. With different subscription level options, your Cat dealer can help you configure exactly what you need to connect your fleet and manage your business, without paying for extras you don't want. Subscriptions are available with cellular or satellite reporting or both.



REMOTE SERVICES

The Cat App helps you manage your assets – at any time – right from your smart device. See fleet location and hours, get critical required maintenance alerts, and even request service from your local Cat dealer.

- + **Remote Flash** – get software updates to one or more machines remotely. You just need a designated person close to the machine to initiate/confirm the update.
- + **Remote Grade** lets you wirelessly manage site plans via Trimble Connect Services.
- + **Operator ID** lets you track machine operation by individual operator using the main display and Product Link.

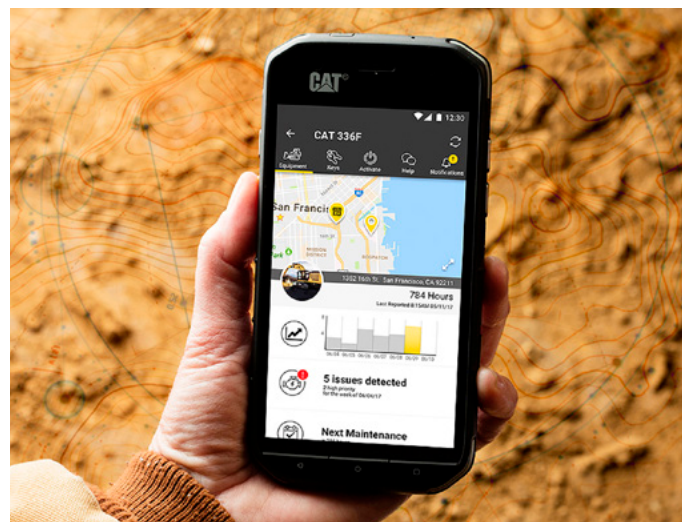

TECHNICAL SPECIFICATIONS

See cat.com for complete specifications.

ENGINE	
Engine Model	Cat C3.6
Emissions	U.S. EPA Tier 4 Final, Japan 2014 (Tier 4 Final), Korea Tier 4 Final, EU Stage V
Build Number	12A
Power Train	Hydrostatic
Net Power* – 2,200 rpm	
SAE J1349	68.8 kW 92 hp
ISO 9249, 80/1269/EEC	68.8 kW 92 hp
Displacement	3.6 L 220 in ³
*Net power is tested per ISO 9249:2007 and SAE J1349:2011 and as advertised is the power available at the flywheel when the engine is equipped with fan, air intake system, exhaust system and alternator.	
All non-road Tier 4 Final, Stage V, Japan 2014 (Tier 4 Final) and Korea Tier 4 Final diesel engines are required to use only Ultra Low Sulfur Diesel (ULSD) fuels containing 15 ppm EPA/10 ppm EU (mg/kg) sulfur or less. Biodiesel blends up to B20 (20% blend by volume) are acceptable when blended with 15 ppm (mg/kg) sulfur or less ULSD. B20 should meet ASTM D7467 specification (biodiesel blend stock should meet Cat biodiesel spec, ASTM D6751 or EN 14214). Cat DEO-ULS™ or oils that meet the Cat ECF-3, API CJ-4, and ACEA E9 specification are required. Consult your OMM for further machine specific fuel recommendations.	
Diesel Exhaust Fluid (DEF) used in Cat Selective Catalytic Reduction (SCR) systems must meet the requirements outlined in the International Organization for Standardization (ISO) standard 22241.	
The air conditioning system on this machine contains the fluorinated greenhouse gas refrigerant R134a (Global Warming Potential = 1430). The system contains 1.8 kg of refrigerant which has a CO ₂ equivalent of 2.574 metric tonnes.	

SERVICE REFILL CAPACITIES		
Fuel Tank	195 L	51.5 gal
Crankcase and Filter	10.5 L	2.8 gal
Final Drives (each side)	10 L	2.6 gal
Final Drives, LGP (each side)	10 L	2.6 gal
Cooling System	19 L	5.0 gal
Transmission/Hydraulic Tank	90 L	23.8 gal
Diesel Exhaust Fluid (DEF) Tank	19 L	4.9 gal

	OPERATING WEIGHT	GROUND PRESSURE
Standard	8338 kg 18,382 lb	39.5 kPa 5.7 psi
LGP	8648 kg 19,066 lb	29.7 kPa 4.3 psi
For machine with ripper, add 554 kg/1,222 lb.		
Specifications shown are for machine equipped with dozer blade, EROPS cab, back up alarm, operator, coolant, lubricants and full fuel tank.		

BLADES	CAPACITY	WIDTH
Standard	1.98 m ³ 2.59 yd ³	2782 mm 109.5 in
Intermediate	1.50 m ³ 1.96 yd ³	2921 mm 115 in
LGP	1.85 m ³ 2.42 yd ³	3149 mm 124 in

DIMENSIONS*	STANDARD	LGP
Track Gauge	1550 mm (61.0 in)	1725 mm (67.9 in)
Width of Tractor (standard shoe)	2010 mm (79.1 in)	2360 mm (92.9 in)
Tractor Height	2765 mm (108.9 in)	2765 mm (108.9 in)
Overall Length (with blade)	4281 mm (168.5 in)	4272 mm (168.2 in)
Length of Basic Tractor (without blade)	3290 mm (129.5 in)	3290 mm (129.5 in)
Ground Clearance	332 mm (13 in)	332 mm (13 in)
With the Following Attachments, Add to Basic Tractor Length:		
Ripper	1177 mm (46.3 in)	1177 mm (46.3 in)
*Abrasion Undercarriage		

Configurations and features may vary by region. Please consult your Cat dealer for availability in your area.

STANDARD & OPTIONAL EQUIPMENT

Standard and optional equipment may vary. Consult your Cat dealer for details.

POWER TRAIN	STANDARD	OPTIONAL
Air cleaner with precleaner, automatic dust ejection and underhood intake	•	
Air cleaner with external precleaner		•
Aluminum bar plate cooling system (radiator, power train)	•	
Automatic traction control	•	
Cat C3.6 diesel engine	•	
Drive, auxiliary	•	
Dual path, closed loop, hydrostatic transmission	•	
Electric fuel pump	•	
Fuel/water separator	•	
Installation, winch		•
Turbocharged aftercooled	•	
ELECTRICAL	STANDARD	OPTIONAL
Alarm, backup	•	
Alternator, 150 amp, heavy duty	•	
Batteries, heavy duty, maintenance free, 1,000 CCA	•	
Diagnostic connector	•	
Four integrated front halogen lights, two rear halogen	•	
Four integrated front LED lights, two rear LED		•
Horn, electric	•	
Starter, electric, 12 V, heavy duty	•	
UNDERCARRIAGE	STANDARD	OPTIONAL
SALT undercarriage (43 section)	•	
Abrasion undercarriage (38 section)		•
Track Pairs		
Track, 460 mm (18 in)		•
Track, 635 mm (25 in)		•
Carrier rollers	•	
Guards, front/rear guiding	•	
Seven roller track frame	•	
Track adjusters, hydraulic	•	
Track rollers, lifetime lubricated	•	

HYDRAULIC	STANDARD	OPTIONAL
Hydraulic pump and oil	•	
Four valve for use with ripper		•
Four valve for use with winch		•
Single lever, three function control	•	
Three valve hydraulics	•	
CAT TECHNOLOGY	STANDARD	OPTIONAL
Cat GRADE with Slope Assist		•
Cat GRADE with 3D		•
Cat Product Link PLE643/PLE743 Cellular	•	
Cat Product Link PLE683/PLE783 Cellular/Satellite		•
Full-color 10 in (254 mm) touchscreen grade display		•
Power Pitch		•
Slope Indicate	•	
Stable blade	•	
ATTACHMENTS	STANDARD	OPTIONAL
Rigid drawbar	•	
Drawbar, towing		•
Front pull device	•	
Machine security system		•
Mounting, winch		•
Ripper, parallelogram, includes three shanks and teeth		•
Winch, hydraulic, high performance		•
Winch, hydraulic, retrieval		•
OTHER	STANDARD	OPTIONAL
Heater, engine, coolant 120 V/240 V		•
Starting aid, ether		•

Not all features are available in all regions. Please check with your local Cat dealer for specific offering availability in your area.

For additional information, refer to the Technical Specifications brochure available at www.cat.com or your Cat dealer.

STANDARD & OPTIONAL EQUIPMENT

Standard and optional equipment may vary. Consult your Cat dealer for details.

OPERATOR ENVIRONMENT	STANDARD	OPTIONAL
Armrests, adjustable	•	
Cab, with air conditioning		•
Cab, polycarbonate windows and air conditioning		•
Coat hook	•	
Controls, seat mounted, fore/aft adjustment	•	
Cup holders	•	
Eco Mode	•	
Electronic Monitoring system with gauge: <ul style="list-style-type: none"> – Chassis slope indication – Diesel exhaust fluid (DEF) – Engine coolant temperature – Fuel level – Hydraulic oil temperature 	•	
Electronic security system	•	
Engine air cleaner service indicator	•	
Engine RPM and gear display	•	
Floor mat, rubber, heavy duty	•	
Foot pads, dash	•	
Hour meter, electronic	•	
Independent forward/reverse speed settings	•	
Mirror, rearview, inside	•	
Power port, 12 volt	•	
Radio, AM/FM Bluetooth®		•
ROPS/FOPS canopy	•	
Seat, air suspended, cloth or vinyl	•	
Seat, air suspension, choice of: <ul style="list-style-type: none"> – Vinyl, heated seat with heated controls – Cloth, heated seat with heated controls – Cloth, heated and ventilated seat with heated controls 		•
Seatbelt, hi-vis retractable 76 mm (3")	•	
Seatbelt buckling indicator/reminder	•	
Single pedal combining decel and brake functions	•	
Sound suppression		•
Speed recall	•	
Storage compartment	•	
Throttle switch, rotary	•	
Travel speed limiter, electronic	•	

Not all features are available in all regions. Please check with your local Cat dealer for specific offering availability in your area.

For additional information, refer to the Technical Specifications brochure available at www.cat.com or your Cat dealer.

For more complete information on Cat products, dealer services and industry solutions, visit us on the web at www.cat.com

© 2020 Caterpillar. All Rights Reserved.

VisionLink and SITECH are trademarks of Trimble Navigation Limited, registered in the United States and in other countries.

Materials and specifications are subject to change without notice. Featured machines in photos may include additional equipment. See your Cat dealer for available options.

CAT, CATERPILLAR, LET'S DO THE WORK, their respective logos, "Caterpillar Corporate Yellow," the "Power Edge" and Cat "Modern Hex" trade dress as well as corporate and product identity used herein, are trademarks of Caterpillar and may not be used without permission.
www.cat.com www.caterpillar.com

AEHQ8308
Build Number: 12A
(N Am, EU, Aus-NZ, Japan)

